

---

## SP 4K/5K Efecto & SP 5K Brilliant Parallel Installation Guide

### 1. Introduction

This inverter can be used in parallel with two different operation modes.

1. Parallel operation in single phase with up to 4 units. The supported maximum output power is 16KW/20KVA.
2. Three units work together to support three-phase equipment, one inverter per phase. The supported maximum output power is 12KW/15KVA.

**NOTE:** If this unit is bundled with share current cable and parallel cable, this inverter is default supported parallel operation. You may skip section 3. If not, please purchase parallel kit and install this unit by following instruction from professional technical personnel in local dealer.

### 2. Package Contents

In parallel kit, you will find the following items in the package:

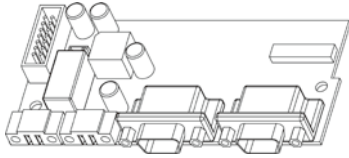

Parallel board



Parallel communication cable



Current sharing cable

### 3. Parallel board installation

This installation steps are only applied to 4K/5K models.

**Step 1:** Remove wire cover by unscrewing all screws.

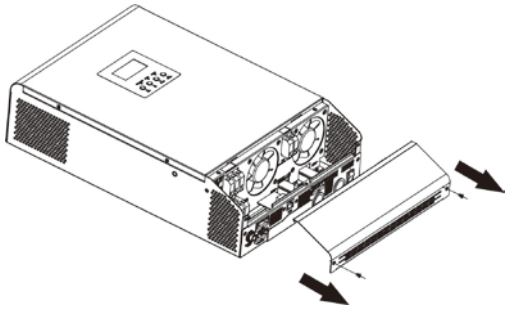

**Step 2:** Remove communication board by unscrewing two screws as below chart.

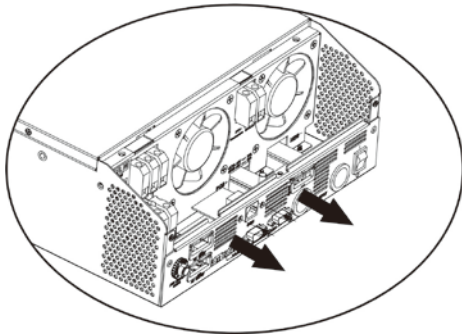

---

**Step 3:** Remove two screws as below chart and remove 2-pin and 14-pin cables. Take out the board under the communication board.

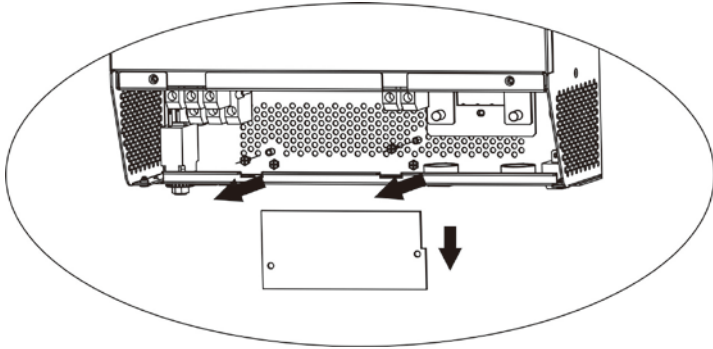

**Step 4:** Remove two screws as below chart to take out cover of parallel communication.

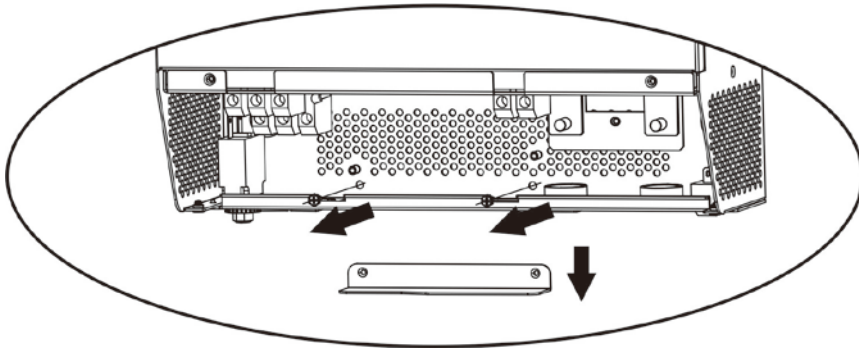

**Step 5:** Install new parallel board with 2 screws tightly.

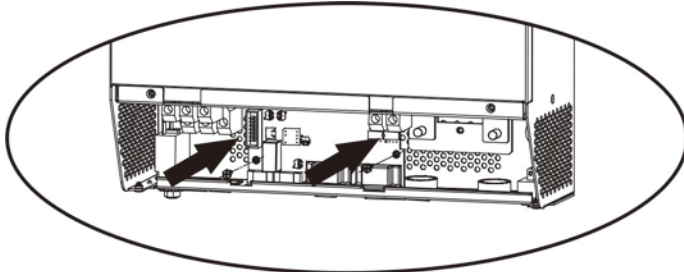

**Step 6:** Re-connect 2-pin and 14-pin to original position.

**Parallel board**

**Communication board**

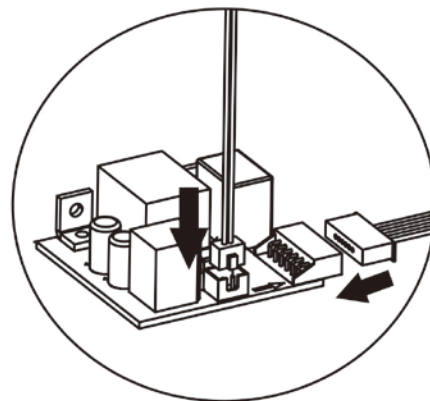
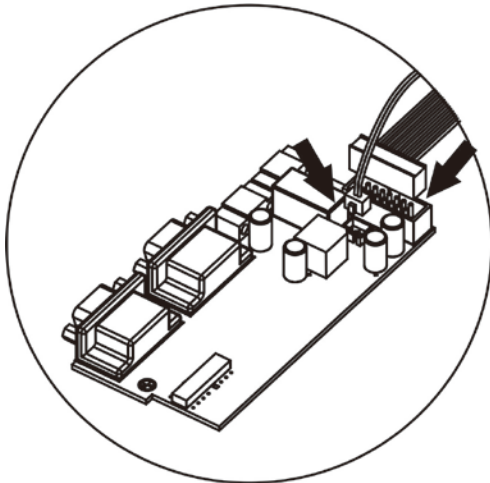

**Step 7:** Put communication board back to the unit.

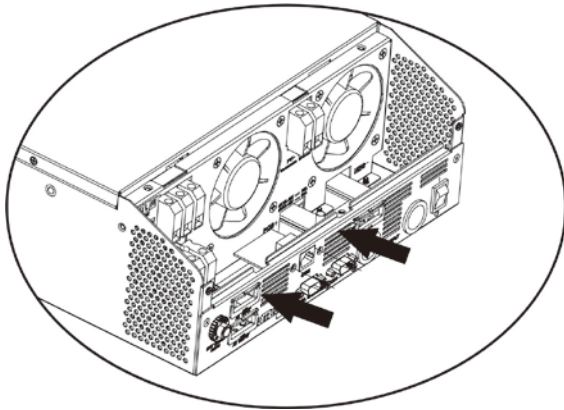

**Step 8:** Put wire cover back to the unit. Now the inverter is providing parallel operation function.

#### 4. Mounting the Unit

When installing multiple units, please follow below chart.

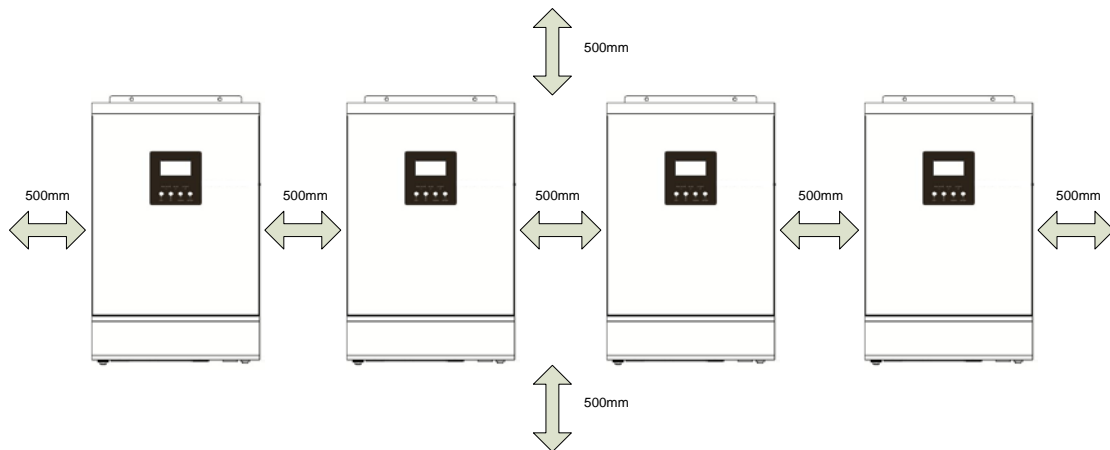

**NOTE:** For proper air circulation to dissipate heat, allow a clearance of approx. 50 cm to the side and approx. 50 cm above and below the unit. Be sure to install each unit in the same level.

#### 5. Battery Connection

**WARNING!** Be sure that all inverters will share the same sets of batteries. Otherwise, the inverters will transfer to fault mode.

**WARNING:** Be sure the length of all battery cables is the same. Otherwise, there will be voltage difference between inverter and battery to cause parallel inverters not working. Follow below chart to connect batteries. All battery cables are connected from inverters to batteries via the same BUS bar.

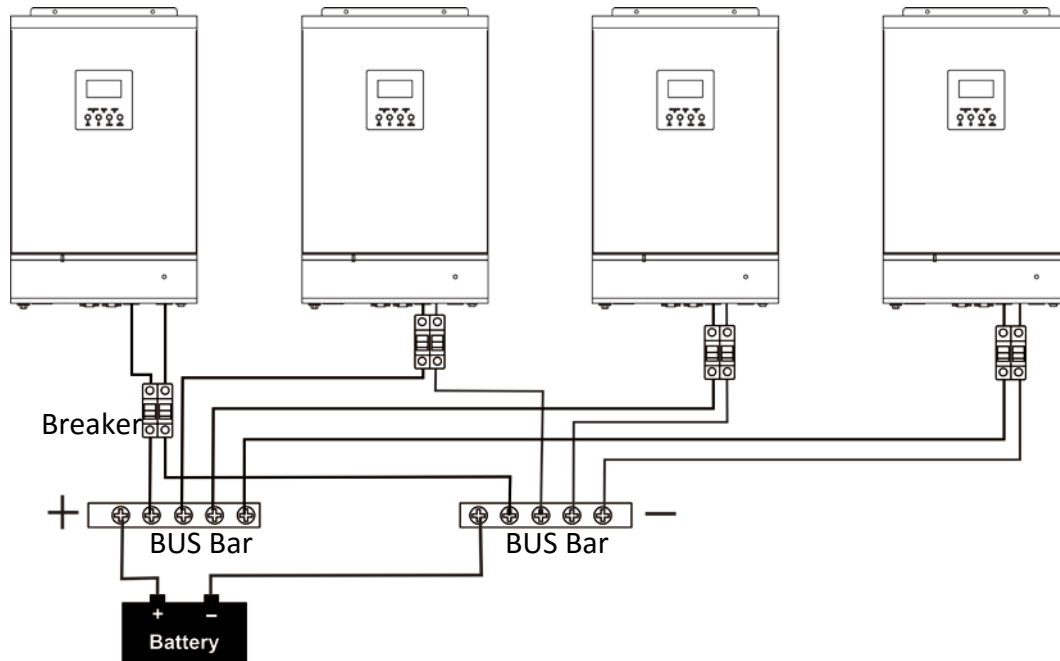

**Recommended battery capacity**

Inverter parallel numbers	2	3	4
Battery Capacity	400AH	600AH	800AH

**NOTE:** Recommended spec of cable from inverter to BUS bar and breaker is listed as below. The cable used from BUS bar to battery should be X pcs of cable from inverter to BUS bar and breaker. X indicates the number of inverters connected in parallel.

**Ring terminal:**

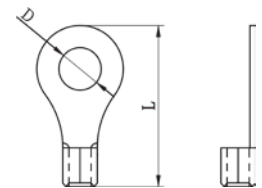

**Recommended battery cable and terminal size:**

Model	Typical Amperage	Battery capacity	Wire Size	Ring Terminal			Torque value
				Cable mm <sup>2</sup>	Dimensions		
					D (mm)	L (mm)	
4KVA	67A	200AH	1*4AWG	22	6.4	33.2	2~ 3 Nm
			2*8AWG	14	6.4	29.2	
5KVA	84A	200AH	1*4AWG	22	6.4	33.2	2~ 3 Nm
			2*8AWG	14	6.4	29.2	

## 6. AC Input Connection

### Parallel in single phase

Connect Line wires of AC input from each unit to Line BUS bar. Connect Neutral wires of AC input from each unit to Neutral BUS bar. Refer to below figure for connection of AC input.

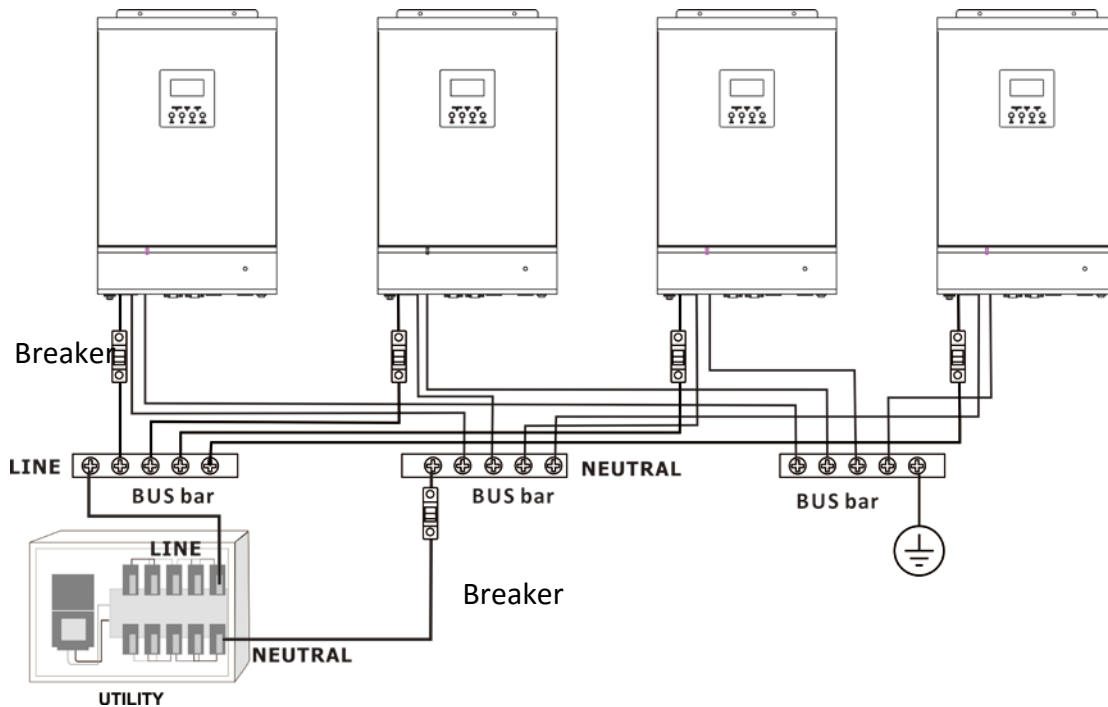

### Support three-phase equipment

Connect Line wires of the inverter to each phase of the utility. Connect Neutral wires of AC input from each unit to Neutral BUS bar. Refer to below figure for connection of AC input.

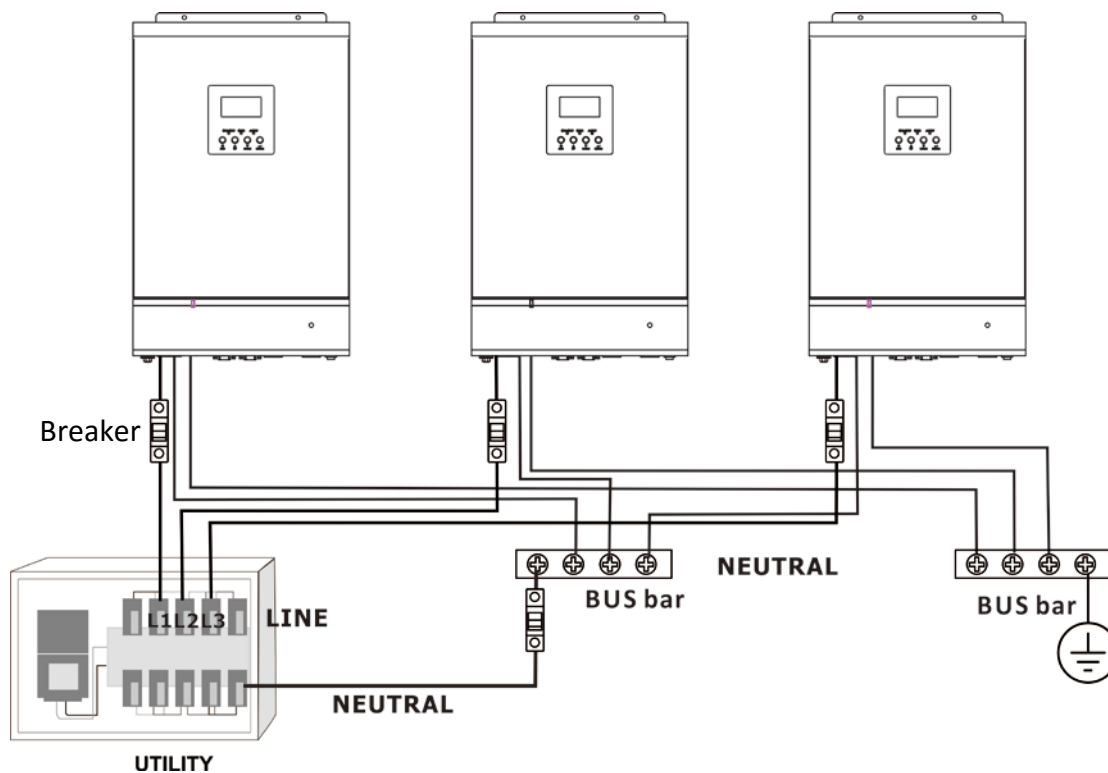

**WARNING:** Only Line wires can be connected breaker. It's not allowed to add breaker into Neutral wires between inverter and the BUS bar. All Neutral wires are connected to the BUS bar directly, and you can add a breaker between the utility and the bus bar in the distributor.

**WARNING:** Be sure the length of all AC input cables is the same to guarantee reliability of sharing current in each unit.

**WARNING:** Recommended spec of cable from inverter to BUS bar and breaker is listed as below. The cable used from BUS bar to AC power should be X pcs of cable from inverter to BUS bar and breaker. X indicates the number of inverters connected in parallel.

**Suggested cable wire and breaker requirement for AC input connection:**

Model	Amperage for breaker	AWG no.	Torque
4KVA	40 A	10 AWG	1.4~1.6Nm
5KVA	50 A	8 AWG	1.4~1.6Nm

## 7. AC Output (Load) Connection

### Parallel in single phase

Connect Line wires of AC output from each unit to Line BUS bar. Connect Neutral wires of AC output from each unit to Neutral BUS bar. Refer to below figure for connection of AC output.

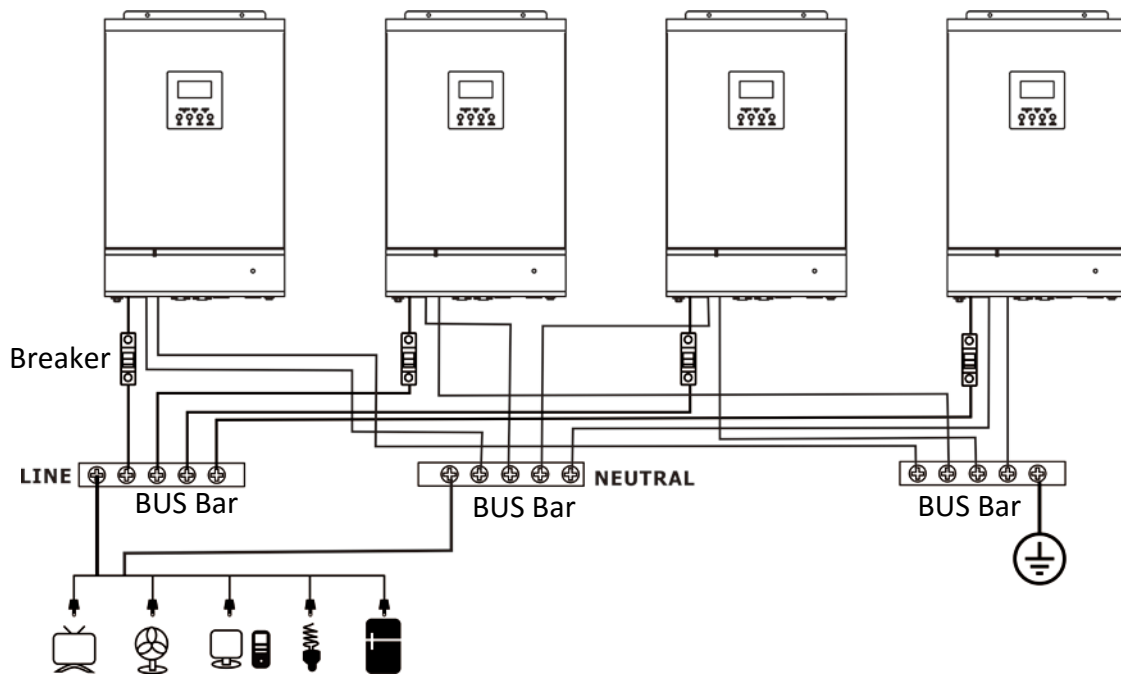

### Support three-phase equipment

Connect Line wires of AC output from each unit to the load. Connect Neutral wires of AC output from each unit to Neutral BUS bar. Refer to below figure for connection of AC output.

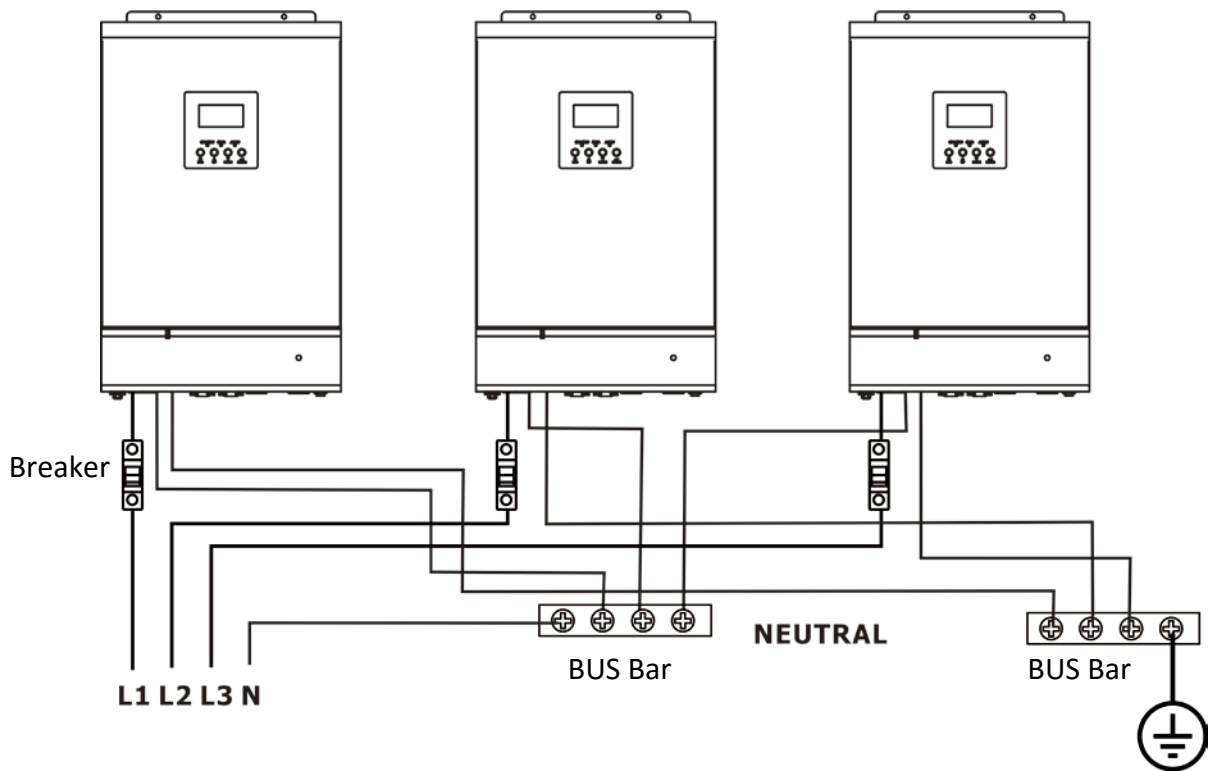

**WARNING:** Only Line wires can be connected breaker. It's not allowed to add breaker into Neutral wires. All Neutral wires are connected to the BUS bar directly.

**WARNING:** Be sure the length of all AC output cables is the same to guarantee reliability of sharing current in each unit.

**WARNING:** Recommended spec of cable from inverter to BUS bar and breaker is listed as below. The cable used from BUS bar to AC output should be X pcs of cable from inverter to BUS bar and breaker. X indicates the number of inverters connected in parallel.

**Suggested cable and breaker requirement for AC output connection:**

Model	Amperage for breaker	AWG no.	Torque
4KVA	40A	10 AWG	1.4~1.6Nm
5KVA	50A	8 AWG	1.4~1.6Nm

**8. PV Connection**

Please refer to user manual of single unit for PV Connection.

**CAUTION:** Each inverter should connect to PV modules separately.

## 9. Parallel Cable Connection

Parallel cable includes parallel communication cable and current sharing cable. Please follow below chart to connect to the inverter.

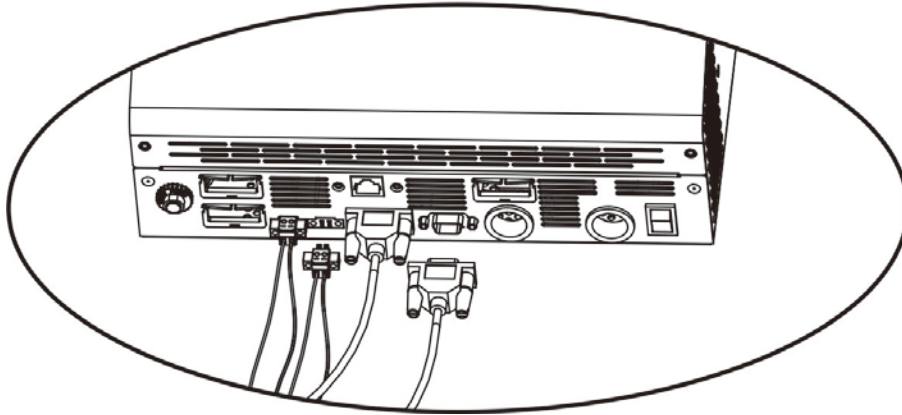

### 9-1. Parallel Operation in Single phase

Two inverters in parallel:

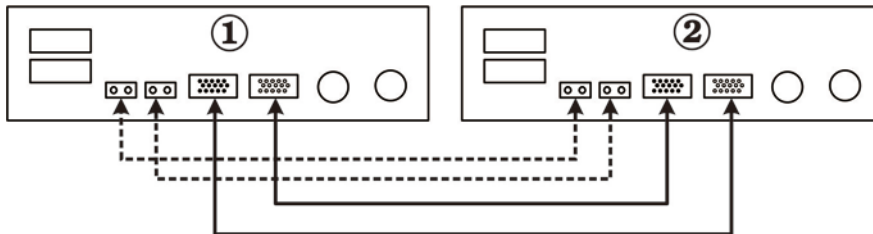

Three inverters in parallel:

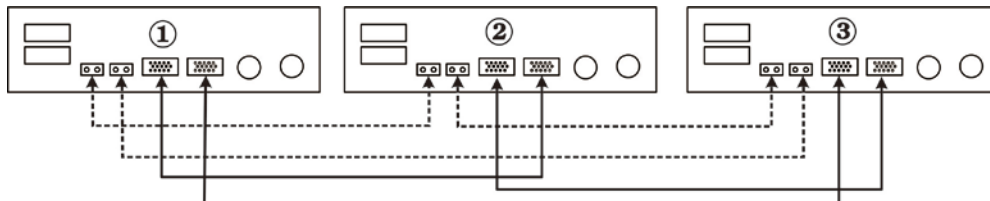

Four inverters in parallel:

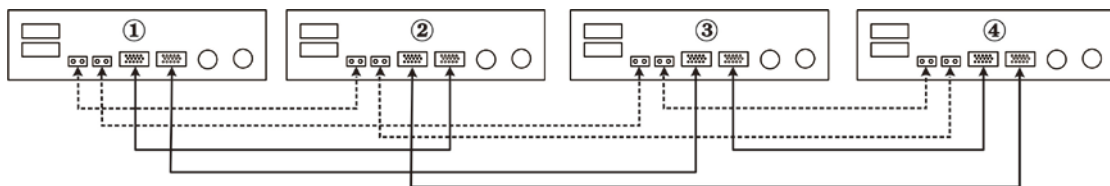

### 9-2. Support 3-phase equipment

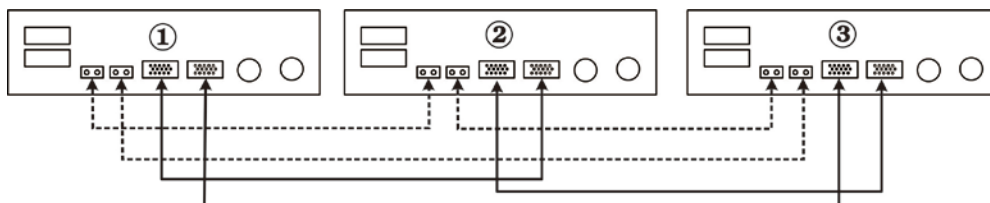

Follow below chart to connect inverters to support 3-phase equipment.







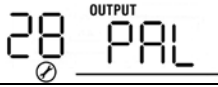

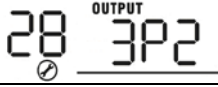
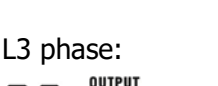

## 10. LCD Setting and Display

**Setting Program:** This setting is only available when the inverter is in standby mode (Switch off).

Program	Description	Selectable option	
28	AC output mode	Single: 	When the units are used in parallel with single phase, please select "PAL" in program 28.  Operation to support three-phase equipment is required to have three inverters. This setting for each unit should be different in L1 phase, L2 phase and L3 phase separately. Please set up this setting corresponding to each phase connection.  No matter it's set for parallel operation or supporting 3-phase equipment, the output source priority only can be set as "Utility" or "SBU". Besides, power saving function will be automatically disabled.
		Parallel: 	
		L1 phase: 	
		L2 phase: 	
		L3 phase: 	

### Fault code display:

Fault Code	Fault Event	Icon on
60	Power feedback protection	
71	Firmware version inconsistent	
72	Current sharing fault	
80	CAN fault	
81	Host loss	
82	Synchronization loss	
83	Battery voltage detected different	

84	AC input voltage and frequency detected different	
85	AC output current unbalance	
86	AC output mode setting is different	

## 11. Commissioning

### Parallel in single phase

Step 1: Check the following requirements before commissioning:

- Correct wire connection
- Ensure all breakers in Line wires of load side are open and each Neutral wires of each unit are connected together.

Step 2: Switch on DC breakers of each unit.

Step 3: Turn on each unit.

LCD display in Master unit	LCD display in Slave unit

**NOTE:** Master and slave units are randomly defined.

Step 4: Switch on all AC breakers of Line wires in AC input. It's better to have all inverters connect to utility at the same time. If not, it will display fault 82 in following-order inverters. However, these inverters will automatically restart. If detecting AC connection, they will work normally.

LCD display in Master unit	LCD display in Slave unit

Step 5: If there is no more fault alarm, the parallel system is completely installed.

Step 6: Please switch on all breakers of Line wires in load side. This system will start to provide power to the load.

### Support three-phase equipment

Step 1: Check the following requirements before commissioning:

- Correct wire connection
- Ensure all breakers in Line wires of load side are open and each Neutral wires of each unit are connected together.

Step 2: Switch on DC breakers of three units.

Step 3: Turn on three units.

LCD display in L1-phase unit	LCD display in L2-phase unit	LCD display in L3-phase unit
<p>The LCD display shows 'INPUT AC 0v', 'P1', and 'OUTPUT 230v'. Below the display is a schematic diagram of a battery pack connected to a light bulb through a switch.</p>	<p>The LCD display shows 'INPUT AC 0v', 'P2', and 'OUTPUT 230v'. Below the display is a schematic diagram of a battery pack connected to a light bulb through a switch.</p>	<p>The LCD display shows 'INPUT AC 0v', 'P3', and 'OUTPUT 230v'. Below the display is a schematic diagram of a battery pack connected to a light bulb through a switch.</p>

Step 4: Switch on all AC breakers of Line wires in AC input. If AC connection is detected and three phases are matched with unit setting, they will work normally. Otherwise, the AC icon will flash and they will not work in line mode.

LCD display in L1-phase unit	LCD display in L2-phase unit	LCD display in L3-phase unit
<p>The LCD display shows 'INPUT AC 230v', 'P1', and 'OUTPUT 230v'. A flashing AC icon is shown on the left. Below the display is a schematic diagram showing a 'BYPASS' switch and a 'CHARGING' indicator.</p>	<p>The LCD display shows 'INPUT AC 230v', 'P2', and 'OUTPUT 230v'. A flashing AC icon is shown on the left. Below the display is a schematic diagram showing a 'BYPASS' switch and a 'CHARGING' indicator.</p>	<p>The LCD display shows 'INPUT AC 230v', 'P3', and 'OUTPUT 230v'. A flashing AC icon is shown on the left. Below the display is a schematic diagram showing a 'BYPASS' switch and a 'CHARGING' indicator.</p>

Step 5: If there is no more fault alarm, the system to support 3-phase equipment is completely installed.

Step 6: Please switch on all breakers of Line wires in load side. This system will start to provide power to the load.

Note 1: To avoid overload occurring, before turning on breakers in load side, it's better to have whole system in operation first.

Note 2: Transfer time for this operation exists. Power interruption may happen to critical devices, which cannot bear transfer time.

## 12. Trouble shooting

Situation		Solution
Fault Code	Fault Event Description	
60	Current feedback into the inverter is detected.	<ol style="list-style-type: none"> <li>1. Restart the inverter.</li> <li>2. If the problem remains, please contact your installer.</li> </ol>
71	The firmware version of each inverter is not the same.	<ol style="list-style-type: none"> <li>1. Update all inverter firmware to the same version.</li> <li>2. If the problem remains, please contact your installer.</li> </ol>
72	The output current of each inverter is different.	<ol style="list-style-type: none"> <li>1. Check if sharing cables are connected well and restart the inverter.</li> <li>2. If the problem remains, please contact your installer.</li> </ol>
80	CAN data loss	<ol style="list-style-type: none"> <li>1. Check if communication cables are connected well and restart the inverter.</li> <li>2. If the problem remains, please contact your installer.</li> </ol>
81	Host data loss	
82	Synchronization data loss	
83	The battery voltage of each inverter is not the same.	<ol style="list-style-type: none"> <li>1. Make sure all inverters share same groups of batteries together.</li> <li>2. If the problem remains, please contact your installer.</li> </ol>
84	AC input voltage and frequency are detected different	<ol style="list-style-type: none"> <li>1. Check the utility wiring connection and restart the inverter.</li> <li>2. If the problem remains, please contact your installer.</li> </ol>
85	AC output current unbalance	<ol style="list-style-type: none"> <li>1. Restart the inverter.</li> <li>2. If the problem remains, please contact your installer.</li> </ol>
86	AC output mode setting is different.	<ol style="list-style-type: none"> <li>1. Switch off the inverter and check LCD setting #28.</li> <li>2. If the problem remains, please contact your installer.</li> </ol>